

\*picture shown with optional  
infeed & outfeed table and casters

 **WEXXAR BEL**

**BEL 5252U**

**SEMI-AUTOMATIC FORM, PACK & SEAL SYSTEM**

**EoL**

**END OF  
LINE**

# BEL 5252U

SEMI-AUTOMATIC FORM, PACK & SEAL SYSTEM

## BEL 5252U INCREASES OPERATOR EFFICIENCY AND ERGONOMICS

Operators can work safely without guarding on the BEL 5252u due to the sensitive photo-eyes which trigger machine operation as well as the ultra-safe Snap Folders

## User-Friendly And Convenient

The BEL 5252u is a semi-automatic form, pack and top and bottom seal system on a unitized platform. This machine is a perfect fit for applications looking for a user-friendly and easy to use system. The BEL 5252u also features the Wexxar Bel ultra-safe Snap Folder technology which eliminates the need for machine guarding and keeps the machine compact.

A unitized platform combines case size adjustments and has a reduced machine footprint. The BEL 5252u comes standard with a KDF Box Stand attachment for convenient and ergonomic operation. Similar to other Bel machines, the BEL 5252u features the Uni-Drive System which keeps the conveyor side belts synchronized to provide a square seal even after years of use.



### ABOUT THE BEL 5252U

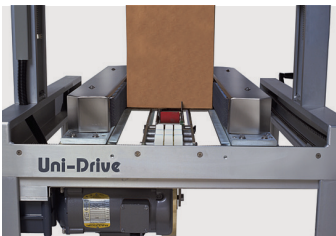

#### REPEATABILITY AND RELIABILITY

*Wexxar Bel's Uni-Drive System synchronizes both side belts, eliminating case skew, ensuring a square seal even after extended periods of use.*



#### EASY CASE SIZE CHANGES

*Tool-less case size changes are simple and quick with change points accessible from both operational sides of the machine.*

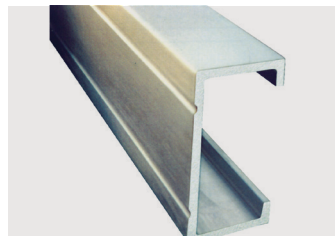

#### LASTING PERFORMANCE

*Corrosion resistant and paint-free construction guards against machine wear and extends machine life.*



#### ON MACHINE INSTRUCTIONS

*User-friendly pictorial guides and color-coded labeling for convenient operation and size changes.*

### COMPLETE SOLUTION

FULLY AUTOMATE YOUR PACKAGING LINE WITH THESE FORMING AND PACKING SOLUTIONS.



#### CONVEYOR

*Flexible conveyors which can be manipulated length and shape wise to fit changing and restrictive packaging applications.*



#### ACCUMULATION TABLE

*Ensures product is delivered continuously and ergonomically to the operator. This allows convenient and quick packing as it keeps the product in reach of the operator.*

## CONFIGURATION

Side View

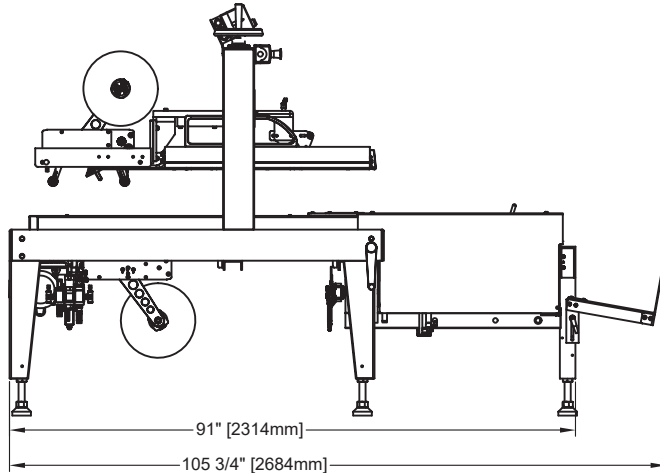

Front View

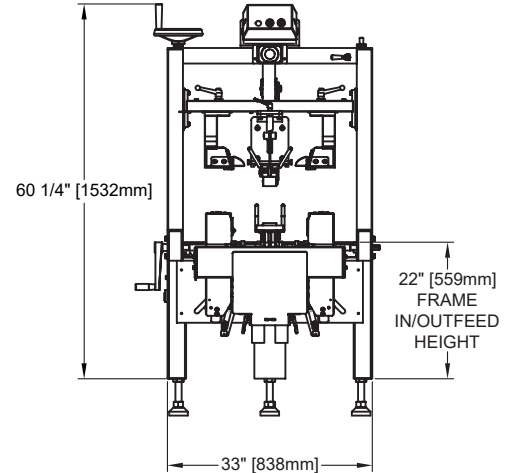

### STANDARD FEATURES

- Dynamic flap-folding system power folds all bottom flaps
- Positive mechanical case hold-down keeps box in place for hands-free loading
- Snap Folder ultra-safe design folds flaps without the use of dangerous flap kickers
- Uni-Drive squaring technology that provide consistent and uniform seal on cases
- Unitized and quick tool-less case size change
- Designed and built in North America with premium materials
- Reliable, consistent "no break" tape advance with Dekka SE-22 stainless steel 2" tape heads

### OPTIONAL MODIFICATIONS

- 3" Tape head upgrade
- Custom voltages
- Modifications for undersize (Consult factory)

### OPTIONAL ACCESSORIES

- Locking Casters
- Outfeed Table or Conveyor
- Accumulation Table

## PRODUCT SPECIFICATIONS

<b>Machine Weight</b>	900 lbs
<b>Machine Dimensions</b>	91"(L) x 33"(W) x 60.25"(H)
<b>Air</b>	0.2 cubic feet per cycle at 80-90 p.s.i.
<b>Electrical</b>	120 Volts, 1 PH, 60 Hz - 10 amp draw
<b>Speeds</b>	up to 15 cases per minute

## CASE SIZE RANGE

	LENGTH	WIDTH	HEIGHT
<b>Minimum</b>	8" 203 mm	6" 152 mm	5" 127 mm
<b>Maximum</b>	22" 559 mm	15.5" 393.7 mm	15.75" 400 mm

Modifications for undersize cases available. Consult factory.

## INFEED/OUTFEED HEIGHT

<b>Minimum</b>	25" (635 mm)
<b>Maximum</b>	32" (813 mm)

Note: Casters add 4" to minimum and maximum height

Specifications are subject to change without notice.

FOR MORE INFORMATION:  
(604) 930-9300 • Wexxar.com



At Wexxar Bel, corrugated container packaging applications are limited only by the imagination. Our Wexxar case formers and case sealers have been installed in nearly 40 countries and consistently bring customers the lowest cost of ownership and the highest standards of safety. Wexxar also offers the BEL line of corrugated box sealers, tapers, and packing systems as well as the IPAK line of tray and bliss formers, stackers, and sealers systems. As part of the ProMach End of Line business line, Wexxar helps our packaging customers protect and grow the reputation and trust of their consumers. ProMach is performance, and the proof is in every package.

13471 Vulcan Way

Richmond, BC, Canada

P: (604) 930-9300

F: (604) 930-9368

E: [Wexxar@ProMachBuilt.com](mailto:Wexxar@ProMachBuilt.com)

[Wexxar.com](http://Wexxar.com)