



*picture shown with optional
infeed & outfeed table and casters

 **WEXXAR BEL®**

BEL 5151U

SEMI-AUTOMATIC FORM, PACK & SEAL SYSTEM

EoL

**END OF
LINE**

BEL 5151U

SEMI-AUTOMATIC FORM, PACK & SEAL SYSTEM

BEL 5151U INCREASES SAFETY AND ACCESSIBILITY.

Operators can work safely without guarding on the BEL 5151u due to the sensitive photo-eyes which trigger machines operation as well as the ultra-safe Snap Folders

User-Friendly And Convenient

The BEL 5151u is a semi-automatic form, pack and bottom seal system on a unitized platform. This machine is a perfect fit for applications with standard case sizes looking for a user-friendly and convenient to use system.

A unitized platform combines case size adjustments and has a reduced machine footprint. The BEL 5151u comes standard with a KDF Box Stand attachment for convenient and ergonomic operation. Similar to other Bel machines, the BEL 5151u features the Uni-Drive System which powers both side belts with a single motor, keeping them synchronized to provide a square seal even after years of use.



ABOUT THE BEL 5151U

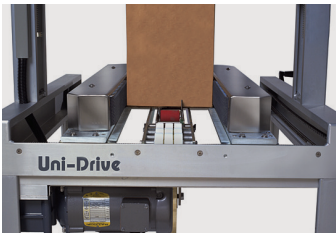

REPEATABILITY AND RELIABILITY

Wexxar Bel's Uni-Drive System synchronizes both side belts, eliminating case skew, ensuring a square seal even after extended periods of use.

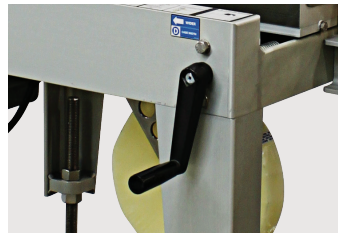

EASY CASE SIZE CHANGES

Tool-less case size changes are simple and quick with change points accessible from both operational sides of the machine.

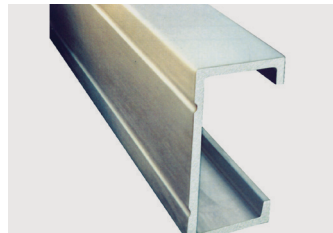

LASTING PERFORMANCE

Corrosion resistant and paint-free construction guards against machine wear and extends machine life.



ON MACHINE INSTRUCTIONS

User-friendly pictorial guides and color-coded labeling for convenient operation and size changes.

COMPLETE SOLUTION

FULLY AUTOMATE YOUR PACKAGING LINE WITH THESE FORMING AND PACKING SOLUTIONS.



BEL 252 CASE SEALER

Fully automatic top and bottom tape case sealer provides an effective and reliable solution for both manual and automatic packaging lines.



CONVEYOR

Flexible conveyors which can be manipulated length and shape wise to fit changing and restrictive packaging applications.



ACCUMULATION TABLE

Ensures product is delivered continuously and ergonomically to the operator. This allows convenient and quick packing as it keeps the product in reach of the operator.

CONFIGURATION

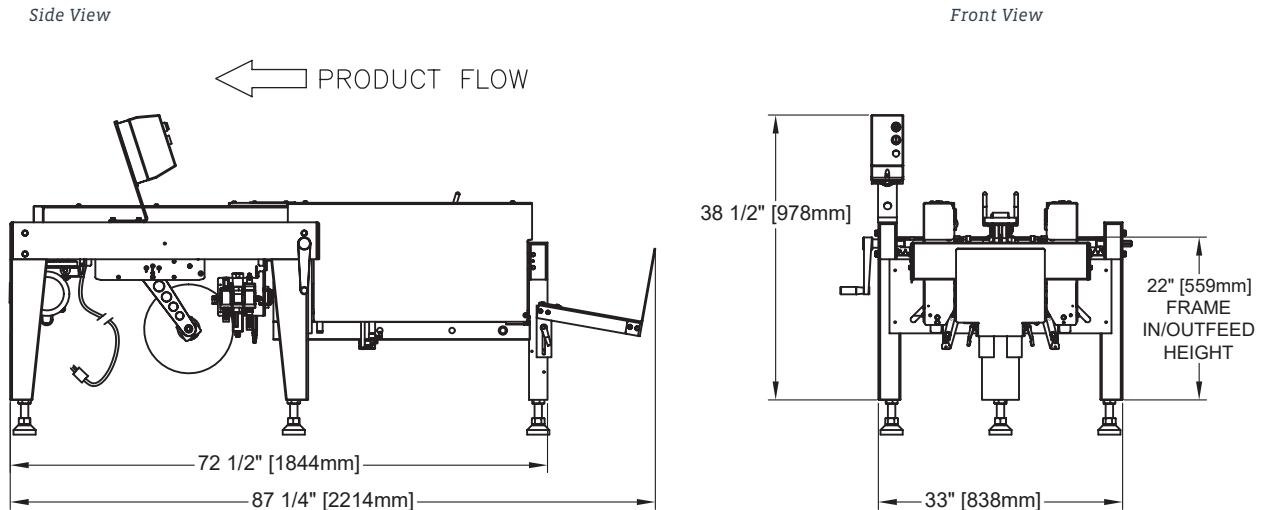

STANDARD FEATURES

- Dynamic flap-folding system power folds all bottom flaps
- Positive mechanical case hold-down keeps box in place for hands-free loading
- Uni-Drive squaring technology that provide consistent and uniform seal on cases
- Unitized and quick tool-less case size change
- Designed and built in North America with premium materials
- Reliable, consistent "no break" tape advance with DEKKA 2" tape heads

OPTIONAL MODIFICATIONS

- Custom voltages
- Dekka stainless steel 3" tape head upgrade
- Modifications for undersize case

OPTIONAL ACCESSORIES

- Locking Casters
- Outfeed Table or Conveyor
- Accumulation Table

PRODUCT SPECIFICATIONS

Machine Weight	540 lbs
Machine Dimensions	72.5"(L) x 33"(W) x 38.5"(H)
Air	0.1 cubic feet per cycle at 80-90 p.s.i.
Electrical	120 Volts, 1 PH, 60 Hz - 10 amp draw
Speeds	up to 15 cases per minute

Specifications are subject to change without notice.

CASE SIZE RANGE

	LENGTH	WIDTH	HEIGHT
Minimum	8" 203 mm	5" 127 mm	4 1/2" 114 mm
Maximum	26" 660 mm	18" 457 mm	Unlimited

Modifications for undersize cases. Consult factory.

INFEED/OUTFEED HEIGHT

Minimum	25" (635 mm)
Maximum	32" (813 mm)

Infeed/Outfeed Height (with adjustable leg extensions)
Note: Casters add 4" to minimum and maximum height



At Wexxar Bel, corrugated container packaging applications are limited only by the imagination. Our Wexxar case formers and case sealers have been installed in nearly 40 countries and consistently bring customers the lowest cost of ownership and the highest standards of safety. Wexxar also offers the BEL line of corrugated box sealers, tapers, and packing systems as well as the IPAK line of tray and bliss formers, stackers, and sealers systems. As part of the ProMach End of Line business line, Wexxar helps our packaging customers protect and grow the reputation and trust of their consumers. ProMach is performance, and the proof is in every package.

13471 Vulcan Way

Richmond, BC, Canada

P: (604) 930-9300

F: (604) 930-9368

E: Wexxar@ProMachBuilt.com

Wexxar.com