

\*picture shown with optional  
infeed & outfeed table and casters

 **WEXXAR BEL®**

**BEL 5150U**

**SEMI-AUTOMATIC FORM, PACK & SEAL SYSTEM**

**EoL**

**END OF  
LINE**

# BEL 5150U

SEMI-AUTOMATIC FORM, PACK & SEAL SYSTEM

## BEL 5150U INCREASES OPERATOR EFFICIENCY AND ERGONOMICS

The BEL 5150u forms and holds the case in place for quick and easy 2 handed case packing and manual top flap folding for case sealing.

## User-Friendly And Convenient

The BEL 5150u is a semi-automatic form, pack and top and bottom seal system on a unitized platform. This machine is a perfect fit for applications with standard case sizes looking for a user-friendly and convenient to use system.

A unitized platform combines case size adjustments and has a reduced machine footprint. The BEL 5150u comes standard with a KDF box stand attachment for convenient and ergonomic operation. Similar to other Bel machines, the BEL 5150u features the Uni-Drive System which powers both side belts with a single motor, keeping them synchronized to provide a square seal even after years of use.

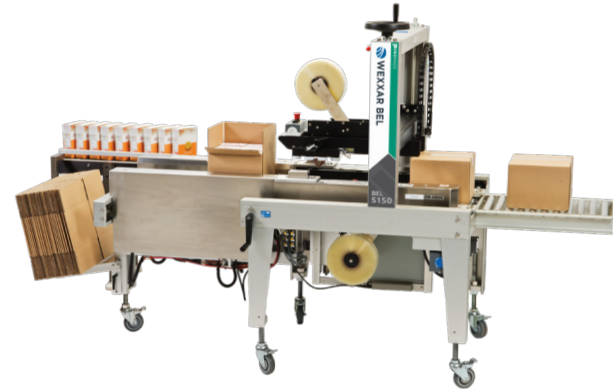

## ABOUT THE BEL 5150U

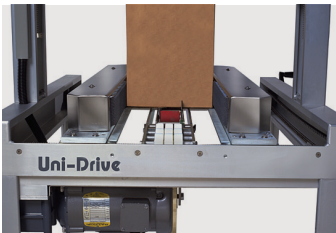

### REPEATABILITY AND RELIABILITY

*Wexxar Bel's Uni-Drive System synchronizes both side belts, eliminating case skew, ensuring a square seal even after extended periods of use.*



### EASY CASE SIZE CHANGES

*Tool-less case size changes are simple and quick with change points accessible from both operational sides of the machine.*

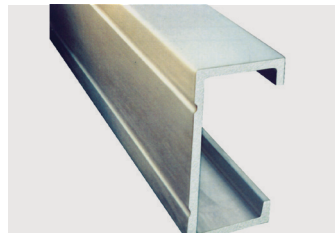

### LASTING PERFORMANCE

*Corrosion resistant and paint-free construction guards against machine wear and extends machine life.*



### ON MACHINE INSTRUCTIONS

*User-friendly pictorial guides and color-coded labeling for convenient operation and size changes.*

## COMPLETE SOLUTION

FULLY AUTOMATE YOUR PACKAGING LINE WITH THESE FORMING AND PACKING SOLUTIONS.



### CONVEYOR

*Flexible conveyors which can be manipulated length and shape wise to fit changing and restrictive packaging applications.*



### ACCUMULATION TABLE

*Ensures product is delivered continuously and ergonomically to the operator. This allows convenient and quick packing as it keeps the product in reach of the operator.*

## CONFIGURATION

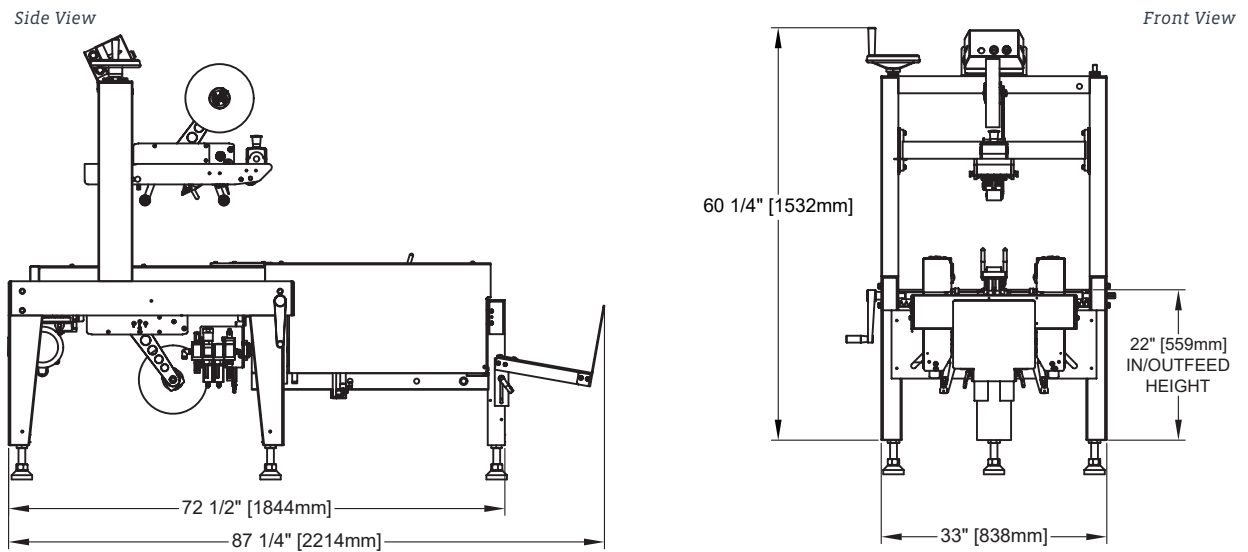

### STANDARD FEATURES

- Dynamic flap-folding system power folds all bottom flaps
- Positive mechanical case hold-down keeps box in place for hands-free loading
- Uni-Drive squaring technology that provide consistent and uniform seal on cases
- Unitized and quick tool-less case size change
- Designed and built in North America with premium materials
- Reliable, consistent "no break" tape advance with Dekka SE-22 stainless steel tape heads

### OPTIONAL MODIFICATIONS

- Dekka stainless steel 3" tape head upgrade
- Custom voltage
- Modifications for undersize and oversize case

### OPTIONAL ACCESSORIES

- Locking Casters
- Outfeed Table or Conveyor
- Accumulation Table

## PRODUCT SPECIFICATIONS

<b>Machine Weight</b>	600 lbs
<b>Machine Dimensions</b>	72.5"(L) x 33"(W) x 60.25(H)
<b>Air</b>	0.1 cubic feet per cycle at 80-90 p.s.i.
<b>Electrical</b>	120 Volts, 1 PH, 60 Hz - 10 amp draw
<b>Speeds</b>	up to 15 cases per minute

Specifications are subject to change without notice.

## CASE SIZE RANGE

	LENGTH	WIDTH	HEIGHT
<b>Minimum</b>	8" 203 mm	5" 127 mm	4 1/2" 114 mm
<b>Maximum</b>	26" 660 mm	18" 457 mm	21" 533 mm

Modifications for undersize and oversize cases available. Consult factory.

### INFEED/OUTFEED HEIGHT

<b>Minimum</b>	25" (635 mm)
<b>Maximum</b>	32" (813 mm)

Note: Casters add 4" to minimum and maximum height



At Wexxar Bel, corrugated container packaging applications are limited only by the imagination. Our Wexxar case formers and case sealers have been installed in nearly 40 countries and consistently bring customers the lowest cost of ownership and the highest standards of safety. Wexxar also offers the BEL line of corrugated box sealers, tapers, and packing systems as well as the IPAK line of tray and bliss formers, stackers, and sealers systems. As part of the ProMach End of Line business line, Wexxar helps our packaging customers protect and grow the reputation and trust of their consumers. ProMach is performance, and the proof is in every package.

13471 Vulcan Way  
Richmond, BC, Canada  
P: (604) 930-9300  
F: (604) 930-9368

E: [Wexxar@ProMachBuilt.com](mailto:Wexxar@ProMachBuilt.com)  
[Wexxar.com](http://Wexxar.com)