



 **WEXXAR BEL®**

BEL 625

NEXT-GENERATION ROBOTIC CASE ERECTOR

WITH FULLY AUTOMATIC ADJUSTMENT

R&E

**ROBOTICS &
END OF LINE**

BEL 625

Next-Generation Robotic Case Erector
with Fully Automatic Adjustment

BEL 625 - ROBOTIC PRECISION. SEAMLESS AUTO-ADJUST

Designed with robotic arms for precision case erecting at 99% efficiency, featuring fully automatic, tool-free adjustments, no complex setups, no specialized training minimizing the need for training.

Robotic Arm Technology with Auto Adjust Feature

The BEL 625 Case Erector is designed for businesses facing skilled labor shortages, frequent case size changes, and varied production demands. It uses robotic arms to provide precision case erecting with up to 99% efficiency. With intuitive automatic changeover technology, the BEL 625 can adjust to new case blank dimensions in under 30 seconds. Its walk-in magazine design allows for easy and ergonomic case loading. The BEL 625 offers a flexible, high-performance automated case erecting solution that enhances profitability and operational efficiency.

Why BEL 625 Is The Smart Choice

- Fully Automatic case erecting and case sealing
- Fully auto-adjust without complex manual adjustments
- Robotic Arm Technology for consistent output
- Easy load, Walk-In Ergonomic Magazine
- High Speed Output running up to 30 cases per minute

ABOUT THE BEL 625



ROBOTIC ARM TECHNOLOGY

Integrated robotic arm technology ensures precise and reliable case forming for consistent, high-efficiency output



MOST CONVENIENT CHANGEOVERS

Easily change case size with auto Adjust by selecting the desired case from the HMI touchscreen



ERGONOMIC WALK-IN LOADING

Easy load, Walk-In ergonomic magazine minimizes operator strain and enables continuous loading during operation

COMPLETE SOLUTION

FULLY AUTOMATE YOUR PACKAGING LINE WITH THESE FORMING AND PACKING SOLUTIONS.



BEL 250 CASE SEALER

Heavy duty fully automatic top and bottom tape case sealer provides an effective and reliable solution for high volume 24/7 operation.



BEL 290 CASE SEALER

High speed fully automatic top and bottom case sealer provides a safe and effective solution for high volume and high speed operations.



BEL 252 CASE SEALER

Compact fully automatic case sealer with Snap Folder technology for reliable, low maintenance performance in space-limited operations.

CONFIGURATION

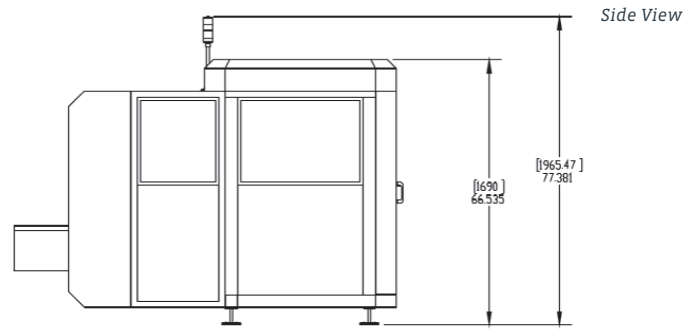
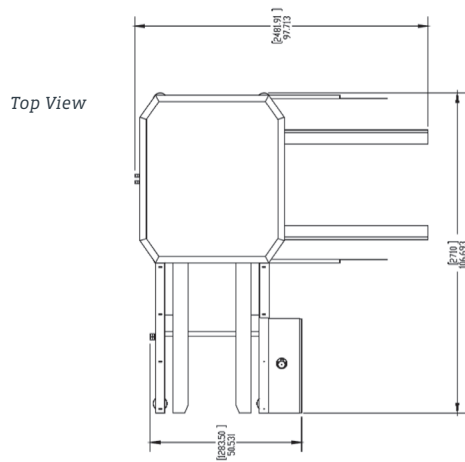

STANDARD FEATURES

- Fully automatic case erecting and sealing eliminates manual handling, reducing labor costs and human error
- Integrated robotic arm technology ensures precise and reliable case forming for consistent, high-efficiency output
- Auto-adjust feature allows seamless transitions between case sizes without manual setup, minimizing downtime
- High-speed operation capable of running up to 30 cases per minute to meet demanding production rates
- Engineered for 99% machine efficiency to maximize uptime and maintain continuous packaging flow
- Adaptive control system automatically adjusts for various corrugate types and thicknesses, reducing need for manual calibration and operator training
- Designed and built in Canada with premium materials

OPTIONAL ACCESSORIES

- Machine Management with tri-light beacon for case jam and tape monitoring
- External Interface Port with power outlet
- Auxiliary Start/Stop/E-Stop Panel
- 3" Tape head upgrade

PRODUCT SPECIFICATIONS

| | |
|---------------------------|--|
| Machine Weight | 2200 lbs |
| Machine Dimensions | 107"(L) x 98"(W) x 67"(H) |
| Air | 30 SCFM; 1 cu.ft. per cycle at 90 p.s.i. (6 bar) |
| Electrical | 240VAC, 3 Phase, 60Hz, 14A FLA |
| Speeds | up to 30 cases per minute |

Specifications are subject to change without notice.

CASE SIZE RANGE*

| | LENGTH | WIDTH | HEIGHT |
|----------------|------------------|------------------|----------------|
| Minimum | 7.5" 190.5 mm | 5.5" 152.4 mm | 6" 152.4 mm |
| Maximum | 19.5" 508 mm | 15" 381 mm | 15" 381 mm |

*These are absolute ranges and may not be achievable on the same machine. Please consult the factory for your specific case size configurations.

INFEEED/OUTFEED HEIGHT

| | |
|----------------|--------------|
| Minimum | 24" (588 mm) |
| Maximum | 29" (635 mm) |

Note: Casters add 4" to minimum and maximum height

FOR MORE INFORMATION:
(604) 930-9300 • Wexxar.com



Wexxar Bel is a leading manufacturer of high-performance case and tray formers, sealers and packers, including the IPAK tray former product line that features innovative designs to precisely create hundreds of tray styles. Wexxar Bel continuously pushes the boundaries of development with patented technologies like the Pin & Dome system to exceed the demands of shifting markets, relieving operational bottlenecks in secondary packaging. Wexxar Bel is a product brand of ProMach, a global leader in packaging line solutions. As part of the ProMach Robotics & End of Line business line, Wexxar Bel helps our packaging customers protect their reputation and grow the trust of their consumers. ProMach is performance, and the proof is in every package. Learn more about Wexxar Bel at www.Wexxar.com and more about ProMach at www.ProMachBuilt.com.

13471 Vulcan Way
Richmond, BC, Canada
P: (604) 930-9300
F: (604) 930-9368

E: Wexxar@ProMachBuilt.com
Wexxar.com