



 **WEXXAR BEL®**

**BEL 615**

**FULLY AUTOMATIC CASE ERECTOR**

**R&E**

**ROBOTICS &  
END OF LINE**

# BEL 615

Fully Automatic Case Erector

## BEL 615 - THE EASY UPGRADE TO FULL AUTOMATION

Designed to replace manual case forming with consistent, square cases. Fully automatic erecting with an ergonomic, low load powered magazine and intuitive, toolless adjustments with no complex setups or specialized training.

## A Powerful Combination of Speed, Reliability, and Easy Operation for Growing Lines

The BEL615 is an entry-level fully automatic case erector, engineered to deliver cost-effective, high-value automation for manufacturers. Capable of forming and bottom sealing up to 15 cases per minute, it offers a powerful combination of speed, reliability, and user-friendly operation for growing production lines.

Its powered low-load magazine minimizes operator strain and enables continuous loading during operation, improving efficiency and safety. The dynamic flap folding system ensures precise, scoreline-accurate folds, while the solid-backed compliant belt drive produces square, flat-bottom cases every time. It also features a full color touchscreen HMI, operator friendly color-coded change handles and pictorial guides and is also optimized for the high performance Dekka tape head, ensuring an effective and reliable case seal.

## Why BEL 615 Is The Smart Choice

- Fully automatic case erecting and bottom sealing
- Easy-load, walk-in ergonomic powered magazine
- Toolless, color-coded changeover in under 5 minutes
- Case forming up to 15 cases per minute
- Dynamic flap folding + compliant belt drive for square, flat-bottom cases

### ABOUT THE BEL 615



#### ERGONOMIC WALK-IN LOADING

*Easy load, Walk-In ergonomic magazine minimizes operator strain and enables continuous loading during operation*



#### PRECISION FORMING

*Dynamic flap folding system ensures precise and accurate folds, while the solid-backed compliant belt drive produces square, flat-bottom cases every time.*



#### RELIABLE SEALING

*Premium DEKKA tape head reduces tape waste and ensures consistent sealing*

### COMPLETE SOLUTION

FULLY AUTOMATE YOUR PACKAGING LINE WITH THESE FORMING AND PACKING SOLUTIONS.



#### BEL 250 CASE SEALER

*Heavy duty fully automatic top and bottom tape case sealer provides an effective and reliable solution for high volume 24/7 operation.*



#### BEL 270 CASE SEALER

*The BEL 270 is a ultra compact fully automatic hot melt case sealer with ultra-safe Snap Folder technology that ensures operator safety without the need for guarding.*



#### BEL 252 CASE SEALER

*Compact fully automatic case sealer with Snap Folder technology for reliable, low maintenance performance in space-limited operations.*

## CONFIGURATION

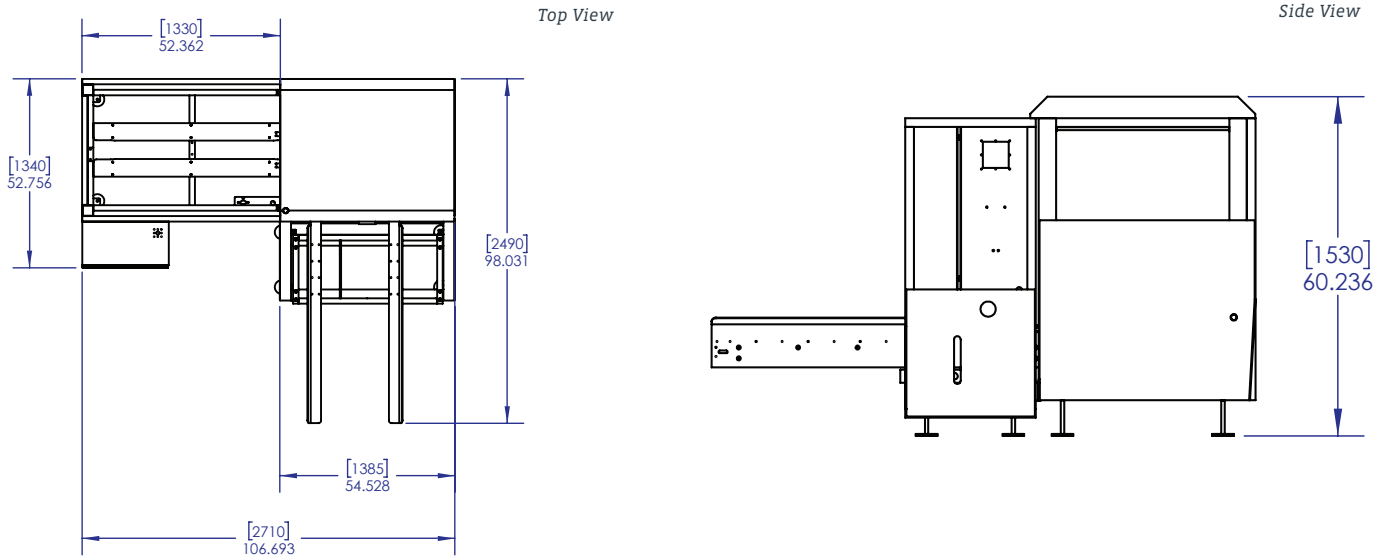

### STANDARD FEATURES

- Entry level automatic case former ideal for applications looking to upgrade from semi-automatic machinery
- Compact design allows machine to fit in small operations
- Color-coded size change labels and minimal amount of change points allow for quick and easy size changes
- User friendly pictorial guides allow for easy training and operation
- Full color 7" HMI touchscreen for easy and intuitive machine operation

- Reliable case sealing with the industry leading high performance Dekka tape head
- Designed and built in Canada with premium materials

### OPTIONAL ACCESSORIES

- Machine Management with tri-light beacon for case jam and tape monitoring
- External Interface Port with power outlet
- Auxiliary Start/Stop/E-Stop Panel
- 3" Tape head upgrade

### PRODUCT SPECIFICATIONS

<b>Machine Weight</b>	1,985 lbs
<b>Machine Dimensions</b>	107"(L) x 98"(W) x 60.23"(H)
<b>Air</b>	20 SCFM; 1.36 cu.ft. per cycle at 90 p.s.i. (6 bar)
<b>Electrical</b>	120VAC, 1 Phase, 60Hz, 5A FLA
<b>Speeds</b>	up to 15 cases per minute

Specifications are subject to change without notice.

### CASE SIZE RANGE\*

	LENGTH	WIDTH	HEIGHT
<b>Minimum</b>	9" 228.6 mm	6" 152.4 mm	5.62" 142.75 mm
<b>Maximum</b>	24" 508 mm	15" 381 mm	18" 457.2 mm

\*These are absolute ranges and may not be achievable on the same machine. Please consult the factory for your specific case size configurations.

### INFEED/OUTFEED HEIGHT

<b>Minimum</b>	24" (588 mm)
<b>Maximum</b>	29" (635 mm)

Note: Casters add 4" to minimum and maximum height

**FOR MORE INFORMATION:**  
(604) 930-9300 • Wexxar.com



Wexxar Bel is a leading manufacturer of high-performance case and tray formers, sealers and packers, including the IPAK tray former product line that features innovative designs to precisely create hundreds of tray styles. Wexxar Bel continuously pushes the boundaries of development with patented technologies like the Pin & Dome system to exceed the demands of shifting markets, relieving operational bottlenecks in secondary packaging. Wexxar Bel is a product brand of ProMach, a global leader in packaging line solutions. As part of the ProMach Robotics & End of Line business line, Wexxar Bel helps our packaging customers protect their reputation and grow the trust of their consumers. ProMach is performance, and the proof is in every package. Learn more about Wexxar Bel at [www.Wexxar.com](http://www.Wexxar.com) and more about ProMach at [www.ProMachBuilt.com](http://www.ProMachBuilt.com).

13471 Vulcan Way  
Richmond, BC, Canada  
P: (604) 930-9300  
F: (604) 930-9368

E: [Wexxar@ProMachBuilt.com](mailto:Wexxar@ProMachBuilt.com)  
[Wexxar.com](http://Wexxar.com)