



*picture shown with optional casters

 **WEXXAR BEL®**

BEL 300

**FULLY AUTOMATIC RANDOM CASE SEALER
WITH ADVANCED AUTO ADJUSTMENT**

R&E

**ROBOTICS &
END OF LINE**

BEL 300

Fully Automatic Random Case Sealer
with Advanced Auto Adjustment

BEL 300 - NO MORE CHANGEOVER DELAYS

Seal random-size cases on a single line with zero manual changeovers. The BEL 300 adjusts instantly and keeps your line moving, efficient, reliable, and built for high-mix operations. Minimizing the need for training.

Advanced Auto Adjustment for Random Case Size Packaging

The BEL 300 Random Case Sealer was designed for operations where multiple case sizes run on a single line. Its light curtain sensor system and linear encoder, enable the machine to instantly read incoming case dimensions and dynamically adjust without returning to a home position, unlike traditional machines.

This seamless size transition is made possible by its three-stage modular design: a high-speed sensing and infeed section, an active flap-folding unit that reduces flap skewing through dynamic motion, and a sealing section powered by our trusted DEKKA tape head for precise and secure closure. The BEL300 further distinguishes itself with its ability to handle up to five cases of varying sizes simultaneously, overlapping motions to reduce wear and maintain peak throughput of up to 25 cases per minute.

WHY BEL 300 IS THE SMART CHOICE?

- Smart light curtain sensors and linear encoder detect and adjust without returning to home position
- Fully automatic random case sealing
- Handles up to 5 random-size cases at once
- Runs up to 25 cases per minute
- Trusted DEKKA tape head for consistent sealing performance

ABOUT THE BEL 300

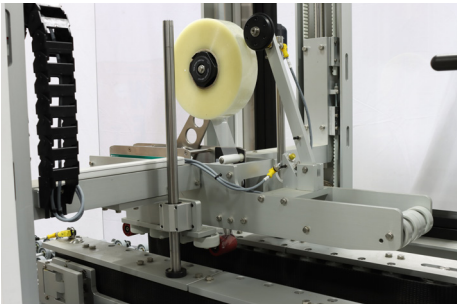

THREE-STAGE MODULAR DESIGN

Includes sensing/infeed, active flap folding, and secure sealing with DEKKA tape head



SMART SENSOR TECHNOLOGY

Real-time case detection with light curtain sensor and encoder



CONSISTENT, HIGH-SPEED OUTPUT

Handles up to 5 random-size cases at once, up to 25 CPM

COMPLETE SOLUTION

FULLY AUTOMATE YOUR PACKAGING LINE WITH THESE FORMING AND PACKING SOLUTIONS.



WF30 WITH AUTO-ADJUST PACKAGE

Auto Adjust Package provides significantly improved OEE with quicker auto changeovers



FLEXIBLE OUTFEED CONVEYOR

Flexible conveyors which can be manipulated length and shape wise to fit changing and restrictive packaging applications.

CONFIGURATION

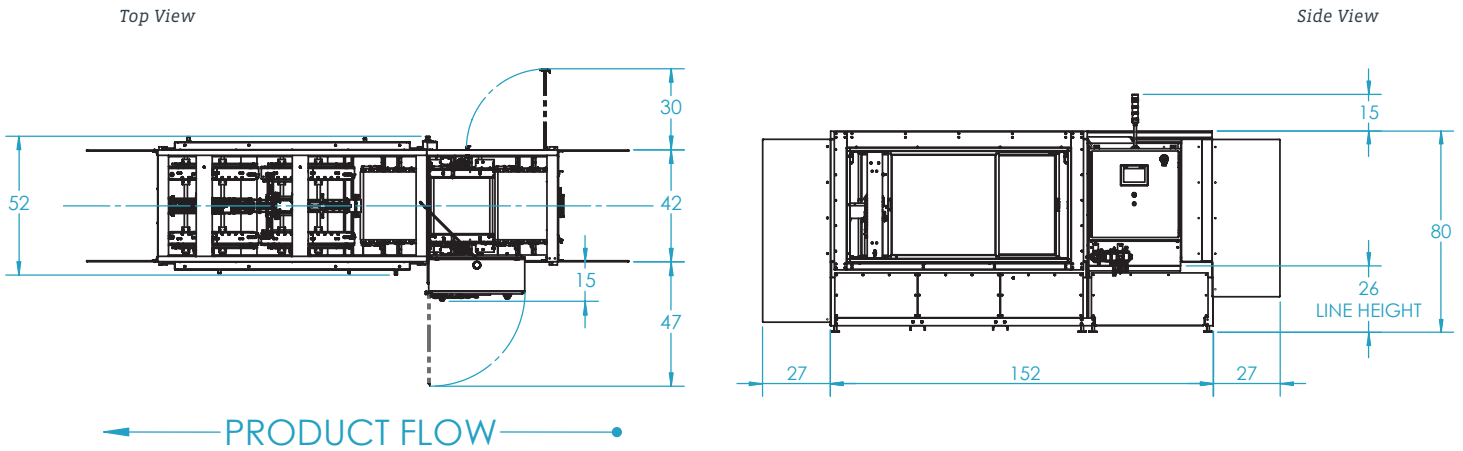

STANDARD FEATURES

- Light curtain sensor system and linear encoder enable the machine to instantly read incoming case dimensions and dynamically adjust without returning to a home position.
- Active flap-folding unit that reduces flap skewing through dynamic motion.
- User-friendly HMI touch screen to control and monitor the machine.
- Designed and built in Canada with high quality components allowing for minimal levels of maintenance and operation in the most demanding working environments.

- Reliable, consistent "no break" tape advance with premium DEKKA stainless steel tape heads.
- Machine Management with tri-light beacon for case jam and tape monitoring

OPTIONAL FEATURES

- Custom voltages
- Locking casters

PRODUCT SPECIFICATIONS

Machine Weight	3,500 lbs
Machine Dimensions	206.75"(L) x 62"(W) x 95.25"(H)
Air	4.15 SCF @25 CPM, 0.166 CF/cycle
Electrical	240VAC, 1 Phase, 60Hz, 27.4A FLA
Speeds	up to 25 cases per minute

Specifications are subject to change without notice.

CASE SIZE RANGE*

	LENGTH	WIDTH	HEIGHT
Minimum	8" 203 mm	5.75" 146 mm	3.875" 98.5 mm
Maximum	24.188" 614 mm	20.25" 514 mm	19" 482 mm

*These are absolute ranges and may not be achievable on the same machine. Please consult the factory for your specific case size configurations.

INFEED/OUTFEED HEIGHT

Minimum	23" (584 mm)
Maximum	28" (711 mm)

Note: Casters add 4" to minimum and maximum height

FOR MORE INFORMATION:
(604) 930-9300 • Wexxar.com



Wexxar Bel is a leading manufacturer of high-performance case and tray formers, sealers and packers, including the IPAK tray former product line that features innovative designs to precisely create hundreds of tray styles. Wexxar Bel continuously pushes the boundaries of development with patented technologies like the Pin & Dome system to exceed the demands of shifting markets, relieving operational bottlenecks in secondary packaging. Wexxar Bel is a product brand of ProMach, a global leader in packaging line solutions. As part of the ProMach Robotics & End of Line business line, Wexxar Bel helps our packaging customers protect their reputation and grow the trust of their consumers. ProMach is performance, and the proof is in every package. Learn more about Wexxar Bel at www.Wexxar.com and more about ProMach at www.ProMachBuilt.com.

13471 Vulcan Way
Richmond, BC, Canada
P: (604) 930-9300
F: (604) 930-9368

E: Wexxar@ProMachBuilt.com
Wexxar.com